

# R & PL Series

1.5-35 HP OIL-LUBRICATED RECIPROCATING AIR COMPRESSORS

- ▶ Automotive
- ▶ Dry Cleaning
- ▶ Service Fleets
- ▶ Industrial
- ▶ Refineries



**CHAMPION**<sup>®</sup>

CHAMPION RECIPROCATING COMPRESSORS...

## The Value Leaders

At Champion, air compressor systems are our only products. We know and understand the application of our products in many different operating environments. Our goal is to provide you with the compressors that fulfill — and exceed — your expectations and requirements.

Because compressed air is an essential utility, dependability is an essential compressor quality. If your compressor goes down, it can hurt your reputation — and your bottom line. Champion reciprocating compressors are proven units, known for their reliability over decades of use. In addition to dependability, you want a compressor that is user-friendly. Champion comes through again, with a wide selection of configurations and options designed for trouble-free operation.

*You can't beat a Champion!*



### Proven Design.

Today's Champion Reciprocating Compressors are the product of decades of design and development.

### Proven Dependability.

You rely on compressed air to perform many tasks efficiently. Champion knows that reliability is one of the main reasons for a purchase. Our slow speed, built-in efficiency through design and the longest compressor warranty in the industry make Champion compressors the proven choice!

### High Performance.

R- and PL-Series compressors are loaded with features designed for day-in, day-out performance. For example, Champion's unique automotive-type domed piston design allows the use of large diameter, low lift valves, while minimizing clearance volume for maximum air delivery.

### Long Life.

Features such as slow speed operation, rugged cast iron crankcase construction, corrosion resistant steel valves and tapered roller-type main bearings all contribute to long life.

### User-friendly Design.

A wide selection of configurations and available options, coupled with serviceability features make it easy to operate and maintain a Champion compressor. Compare all the features on the pages that follow. You'll discover why Champion is the value leader in reciprocating compressors for a broad range of automotive and industrial applications.

# The Solution to Your Application



## Select the configuration that matches your application.

With many models from which to choose in both single-stage and two-stage, we can match your needs exactly. These configurations, combined with a wide choice of options, provide all the components for a customized installation. They are available in both R-Series splash-lubricated and PL-Series pressure-lubricated models.

## Tank-mounted Air Compressors

Available with horizontal or space-saving vertical tanks, two-stage air compressors compress air to a higher pressure than single stage compressors.

## Base-mounted Air Compressors

Designed for installations where air tanks are remotely located.

## Duplex Air Compressors

For extra air delivery when you need it without wasted space. Plus the flexibility of single operation, alternating between compressors, or duplex operation to meet high air demand.

## Gasoline or Diesel Engine Powered Air Compressors

Truck and utility bed mounting design makes these compressors ideal for fleet and field service. Ideal for applications where electricity is not available.

## Bare Compressor Pumps

Provide dependable service for industrial applications, pump replacement or OEM applications. The rugged pump design assures reliability and long maintenance intervals.

## Receivers

Receivers are ASME approved and include a pressure gauge, pressure relief valve, drain valve and service valve.



# Splash-Lubricated R-Series

Loaded with rugged features, the R-Series splash-lubricated compressors deliver high performance, long life and tremendous value.

## 1 Multi-finned cylinders

Cooler operating temperatures result in longer life and consistent performance over time.

## 2 Integral cylinder/head

Gasketless design eliminates the possibility of blown head gaskets for trouble-free operation.

## 3 Balanced pistons

Aluminum alloy first-stage piston is weight-matched to the cast iron second-stage piston, ensuring proper balance.

## 4 Piston rings

Two compression rings and one oil control ring provide excellent oil control, and high efficiency air delivery.

## 5 Lightweight connecting rods

High-density, die-cast aluminum alloy rods minimize reciprocating weight. An integral, precision-bored crankpin bearing and a needle bearing for the piston pin properly distribute bearing loads for longer bearing life than bushings.

## 6 Pressure relief valves

Located in interstage and discharge.

## 7 Intercoolers

Large-diameter finned tubing is positioned to obtain the greatest cooling effect between stages for maximum compressor efficiency.

## 8 Optimized cooling fan/flywheel

Precision balanced flywheel has fan blades for optimum compressor cooling and life.

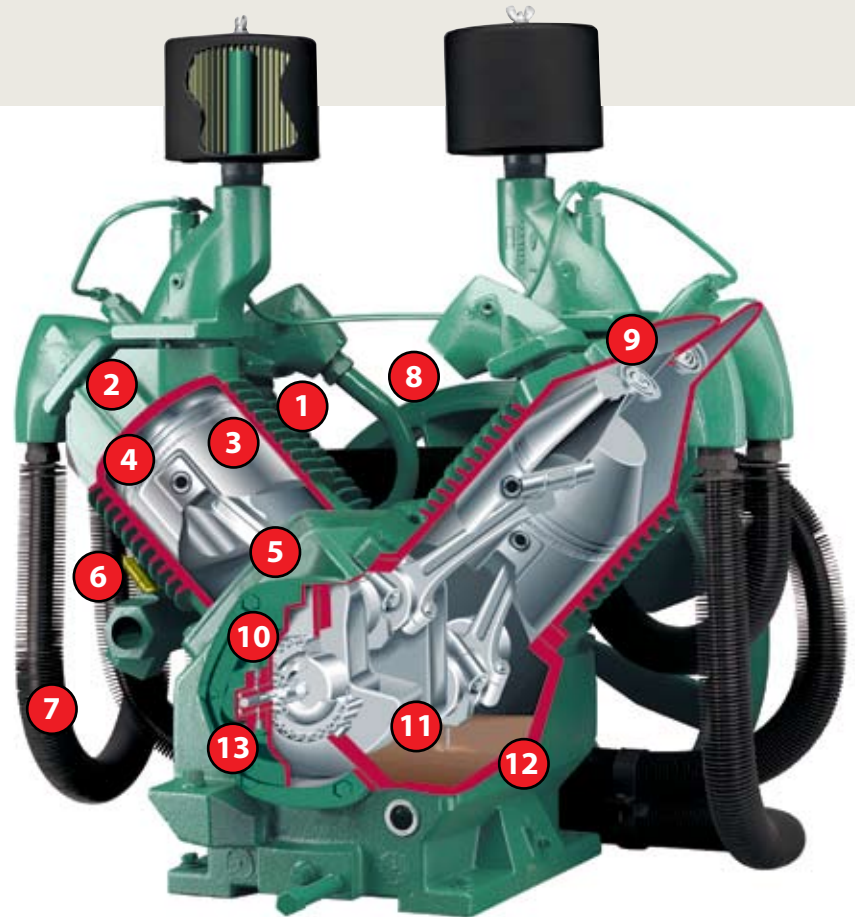

## 9 Reliable, high-flow valves

Single-unit, disc-type valves provide low lift and long life. Discs are made of corrosion resistant Swedish steel. Valves are easily serviced by removing the manifolds only.

## 10 Oversized main bearings

Tapered roller-type main bearings provide full contact and support of the crankshaft plus delivers the longest possible life.

## 11 Balanced crankshaft

Constructed of rugged ductile iron with large diameter throws for minimum bearing loads and counterweights to minimize vibration.

## 12 Large capacity crankcase

Rugged cast iron oil reservoir has convenient sight gauge glass, corner oil fill boss and large oil drain.

## 13 Loadless starting

Positive acting, governor-type centrifugal unloader assures longer motor life by allowing the compressor to start unloaded every time.

# Pressure-Lubricated PL-Series

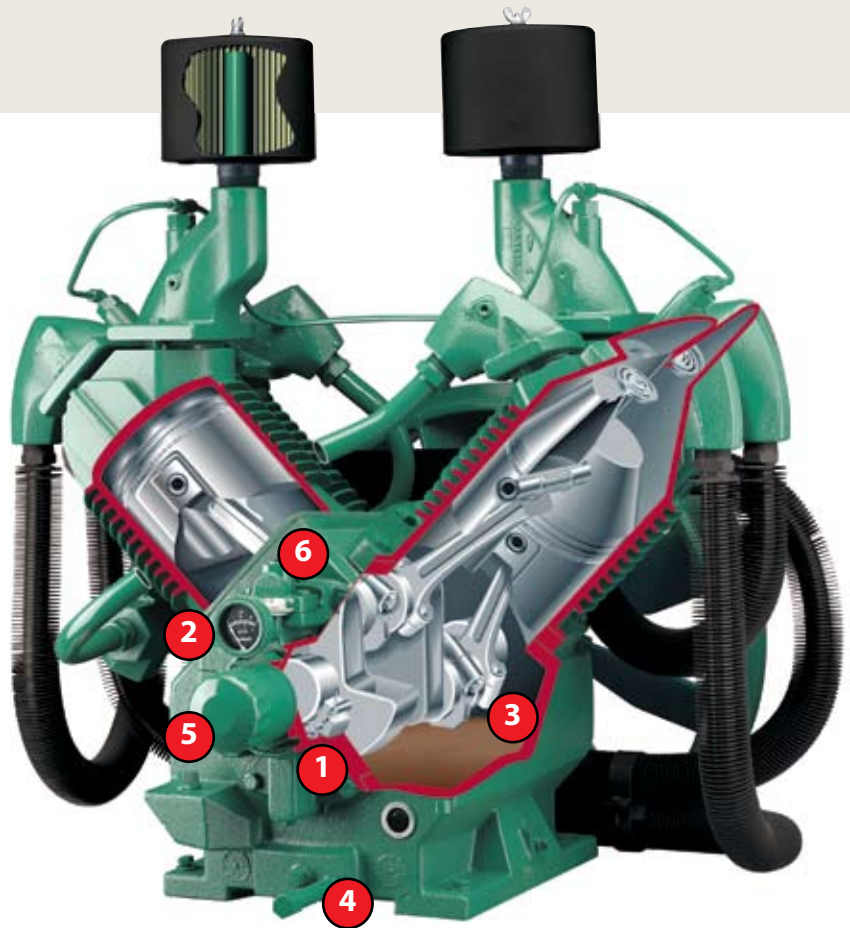

The PL-Series compressor has been designed to operate in extreme duty applications and is also an alternative to an R-Series unit. Because the PL-Series can operate up to 250 psi, in remote locations or in off-level operations, it is a true industrial use compressor. Champion is so confident in the way it has engineered and built its products, it offers a 5-year warranty on the compressor pump. The PL-Series features domed pistons, integral cylinder head, disc valves and an oil pump that provides lubricant to all crucial parts of the compressor. From its extra heavy duty design to its ease of maintenance, the Champion PL-Series exemplifies reliability, durability and quality.

## 1 Pressure lubrication

Crankshaft and connecting rod bearings are pressure lubricated for extended life.

## 2 Oil pressure gauge

Mounted on the front of the compressor for an excellent view and easy pressure monitoring.

## 3 Babbitt bearings

Replaceable bearing makes repairs easy and inexpensive.

## 4 Lubricant filtration

An external spin on oil filter and an internal oil inlet screen protect internal components from damaging debris.

## 5 Positive displacement oil pump

Provides lubricant to all critical areas of the compressor pump that require lubrication.

## 6 Loadless starting

Hydraulic unloader with-factory set pilot valve provides easy, loadless starts and low oil pressure protection for unattended operation.

# Quality Accessories

Many options are available to help you develop a Champion compressor package that exactly matches your specific operating requirements.



## 1 Magnetic starter

*(included as standard on most models)*

For thermal overload protection, a starter is required for units 3 HP and up. May be mounted or unmounted.

## 2 Air-cooled or water-cooled aftercooler

The factory mounted, heavy duty, air-cooled aftercooler effectively reduces up to 65% of the moisture from discharged compressed air.



## 3 Automatic tank drain

Pneumatic drain operates from a centrifugal unloader.

## 4 Vibration isolators

Isolates the compressor unit from the foundation or floor. Reduces noise and protects the unit from any out-of-level floor situation that could cause vibration and damage.



## 5 Low oil level monitor

Low Oil Level Monitor shuts down the unit when oil levels are below an adequate level. Prevents the unit from restarting if oil levels are not at an adequate level.

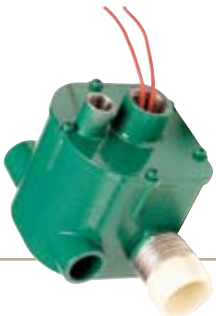



## 6 Refrigerated air dryer

Cools compressed air to a 33°–39° dew point, eliminating additional downstream condensation in the air line. Normally, a dryer should be used in conjunction with an aftercooler. Refrigerated and desiccant dryer types are available.



## 7 DPR Control Panel

The Microprocessed Duplex Relay Panel was created for controlling a duplex air compressor package. The controller includes visual maintenance and shut down alarms.

## 8 Champion Compressor Lubricants

ChampLub lubricants are blended specifically for Champion compressors for use in harsh compressor environments. They are sourced from extremely stable base stocks and enhanced with carefully selected additive packages to provide long life and superior protection. ChampLub lubricants are suitable for a variety of applications and are available as a mineral oil, synthetic or food-grade synthetic.

Available in 55-gallon drums, five-gallon pails, one-gallon bottles and one-quart bottles.



## Other Options

- ▶ Power Monitor that shuts down unit in the event of single phasing, low voltage or phase reversal
- ▶ Constant Speed Control which prevents excessive motor start/stop cycles while saving energy
- ▶ Dual Control will allow the compressor to run either in start/stop or constant speed mode
- ▶ NEMA 4 rated parts available
- ▶ Alternate voltages and TEFC, ODPHE, TEFCHE Electric Motors

## BARE-PUMP DIMENSIONS

Item	R-10D, R-15B, PL-15 Inch	R-30D & PL-30 Inch	R-40A & PL-40 Inch	R-70A & PL-70 Inch
A Base – Width	10	11 $\frac{1}{8}$	12 $\frac{7}{8}$	12 $\frac{7}{8}$
B Bolt-down – Width	4 $\frac{3}{8}$	4 $\frac{13}{16}$	5 $\frac{1}{16}$	5 $\frac{1}{16}$
C Bolt-down to Edge	$\frac{5}{8}$	$\frac{3}{4}$	$\frac{3}{4}$	$\frac{3}{4}$
D Base to Crank CTR	5 $\frac{1}{2}$	7	7 $\frac{5}{16}$	7 $\frac{7}{8}$
E Overall Width	16 $\frac{7}{8}$	26	30	33 $\frac{1}{2}$
F Overall Height	23 $\frac{1}{4}$	23 $\frac{9}{16}$	32	33 $\frac{3}{16}$
H HP Exh. Opening Manifold	$\frac{3}{4}$ " Tubing	$\frac{3}{4}$ NPT	1" Tubing	1 $\frac{1}{4}$ NPT
I Bolt-down Hole Diameter	1 $\frac{1}{32}$	1 $\frac{1}{32}$	$\frac{9}{16}$	$\frac{9}{16}$
J Base — Depth	7 $\frac{1}{2}$	9 $\frac{3}{4}$	12	13 $\frac{1}{4}$
K Bolt-down — Depth	5 $\frac{3}{4}$	8 $\frac{1}{16}$	10	11 $\frac{1}{4}$
L Bolt-down to Edge	$\frac{7}{8}$	2 $\frac{3}{32}$	1	1
M Bolt Hole to Wheel (Max.)	3	3 $\frac{1}{4}$	5 $\frac{3}{4}$	5 $\frac{3}{4}$
N Flywheel — Width	2 $\frac{1}{2}$	2 $\frac{23}{32}$	3 $\frac{1}{2}$	3 $\frac{1}{2}$
O Crank Diameter	1 $\frac{5}{16}$	1 $\frac{3}{4}$	2 $\frac{1}{4}$	2 $\frac{1}{4}$
P Flywheel Diameter	16 $\frac{1}{2}$	18 $\frac{7}{8}$	22	22 $\frac{3}{16}$
Q Flywheel Grooves	2VB*	2VB*	3VB*	3VB*
R Overall Depth	20	22 $\frac{3}{8}$	27 $\frac{1}{2}$	28 $\frac{3}{4}$
Approximate Shipping Weight (lbs.)	125	220	440	570

\*VB: V Belt

R-10D, R-15B, PL-15A

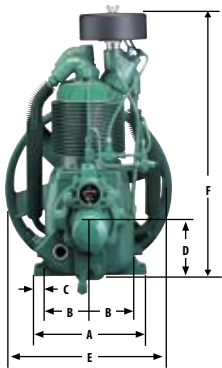

R-30D &amp; PL-30A

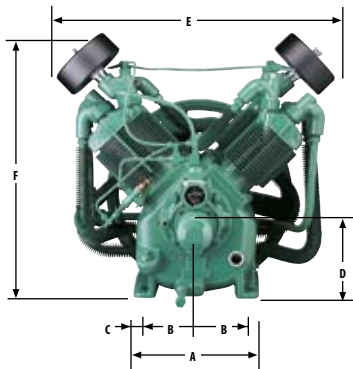

R-40A &amp; PL-40A

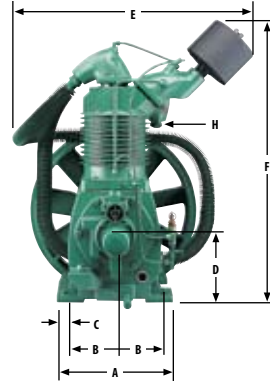

R-70A &amp; PL-70A

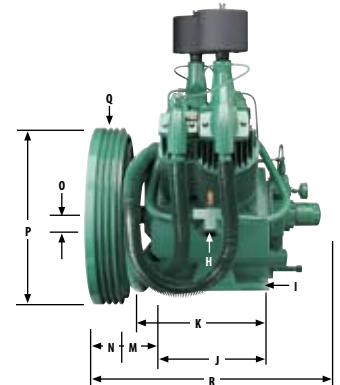
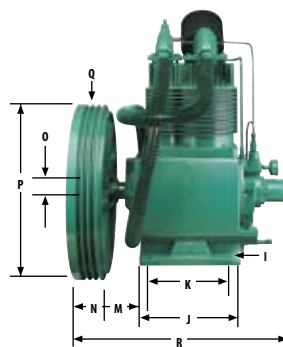
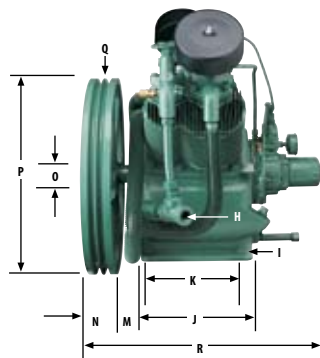
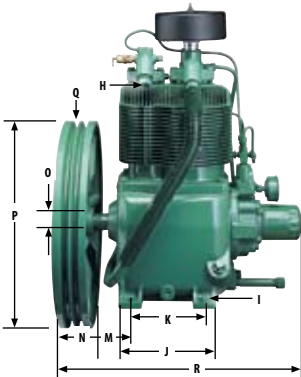
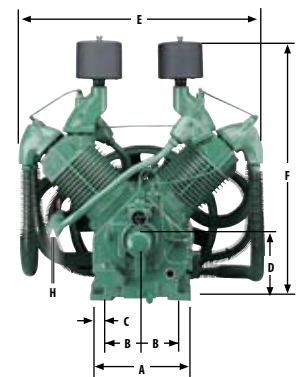



## SPECIFICATIONS

HORIZONTAL TANK MOUNTED UNITS — ELECTRIC DRIVEN								125 PSI Rating*			175 PSI Rating*			250 PSI Rating*		
Motor HP	Tank Cap Gal.	R-Series CASRSA	Pump Comp Model	PL-Series CBSPLA	Pump Comp Model	L x W x H Dimensions inches	Aprox. Ship Wt.lbs.	RPM	CFM Displ.	CFM Del'y	RPM	CFM Displ.	CFM Del'y	RPM	CFM Displ.	CFM Del'y
1½	30	HR1-3	R-10D	NA	NA	41½ x 20¼ x 44½	300	575	11.2	6.0	542	10.5	5.3	NA	NA	NA
1½	60	HR1-6	R-10D	NA	NA	51½ x 23¼ x 49	400	575	11.2	6.0	542	10.5	5.3	NA	NA	NA
1½	80	HR1-8	R-10D	NA	NA	66½ x 23¼ x 49	425	575	11.2	6.0	542	10.5	5.3	NA	NA	NA
2	30	HR2-3	R-10D	NA	NA	41½ x 20¼ x 44½	320	765	14.9	8.3	725	14.1	7.5	NA	NA	NA
2	60	HR2-6	R-10D	NA	NA	51½ x 23¼ x 49	425	765	14.9	8.3	725	14.1	7.5	NA	NA	NA
2	80	HR2-8	R-10D	NA	NA	66½ x 23¼ x 49	455	765	14.9	8.3	725	14.1	7.5	NA	NA	NA
3	60	HR3-6	R-15B	HPL3-6	PL-15A	51½ x 23¼ x 49	425	485	14.1	10.9	440	12.8	9.7	380	11.0	8.0
3	80	HR3-8	R-15B	HPL3-8	PL-15A	66½ x 23¼ x 49	485	485	14.1	10.9	440	12.8	9.7	380	11.0	8.0
3	120	HR3-12	R-15B	HPL3-12	PL-15A	70½ x 25 x 52¾	725	485	14.1	10.9	440	12.8	9.7	380	11.0	8.0
5	60	HR5-6	R-15B	HPL5-6	PL-15A	51½ x 23¼ x 49	445	805	23.5	19.1	710	20.7	16.5	640	18.6	13.6
5	80	HR5-8	R-15B	HPL5-8	PL-15A	66½ x 23¼ x 49	535	805	23.5	19.1	710	20.7	16.5	640	18.6	13.6
5	120	HR5-12	R-15B	HPL5-12	PL-15A	70½ x 25 x 52¾	765	805	23.5	19.1	710	20.7	16.5	640	18.6	13.6
7½	80	HR7F-8	R-15B	HPL7F-8	PL-15A	66½ x 23¼ x 49	570	990	28.7	23.9	990	28.7	23.1	870	25.5	18.2
7½	120	HR7F-12	R-15B	HPL7F-12	PL-15A	70½ x 23¼ x 52¾	765	990	28.7	23.9	990	28.7	23.1	870	25.5	18.2
7½	80	HR7-8	R-30D	HPL7-8	PL-30A	66½ x 23¼ x 52¾	665	670	39.6	30.0	575	33.5	25.8	520	30.2	21.3
7½	120	HR7-12	R-30D	HPL7-12	PL-30A	70½ x 25 x 53¼	860	670	39.6	30.0	575	33.5	25.8	520	30.2	21.3
10	80	HR10-8	R-30D	HPL10-8	PL-30A	66½ x 23¼ x 49¼	675	810	47.3	37.3	740	43.1	34.8	640	37.1	27.5
10	120	HR10-12	R-30D	HPL10-12	PL-30A	70½ x 25 x 53¼	890	810	47.3	37.3	740	43.1	34.8	640	37.1	27.5
10	250	HR10-25	R-30D	HPL10-25	PL-30A	87½ x 30 x 60½	1295	810	47.3	37.3	740	43.1	34.8	640	37.1	27.5
15	80	HR15F-8	R-30D	HPL15F-8	NA	66½ x 23¼ x 49¼	675	1045	60.9	50.2	1045	60.9	49.0	900	52.5	42.6
15	120	HR15F-12	R-30D	HPL15F-12	PL-30A	70½ x 25 x 53¼	840	1045	60.9	50.2	1045	60.9	49.0	900	52.5	42.6
15	250	HR15F-25	R-30D	HPL15F-25	PL-30A	88½ x 30 x 60½	1275	1045	60.9	50.2	1045	60.9	49.0	900	52.5	42.6
15	120	HRA15-12	R-40A	HPL15-12	PL-40A	72 x 27½ x 62	1110	890	71.1	59.0	770	61.5	53.7	700	55.9	45.8
15	250	HRA15-25	R-40A	HPL15-25	PL-40A	89 x 30¼ x 64	1495	890	71.1	59.0	770	61.5	53.7	700	55.9	45.8
20	120	HRA20-12	R-70A	HPL20-12	PL-70A	72 x 27½ x 64½	1325	770	109.0	91.9	655	93.0	76.7	545	77.4	64.1
20	250	HRA20-25	R-70A	HPL20-25	PL-70A	89 x 30¼ x 71½	1790	770	109.0	91.9	655	93.0	76.7	545	77.4	64.1
25	120	HRA25-12	R-70A	HPL25-12	PL-70A	72 x 27½ x 64½	1365	890	127.8	102.1	770	109.4	90.1	660	93.7	76.8
25	250	HRA25-25	R-70A	HPL25-25	PL-70A	89 x 30¼ x 71½	1735	890	127.8	102.1	770	109.4	90.1	660	93.7	76.8
30	120	HRA30-12	R-70A	HPL30-12	PL-70A	72 x 27½ x 64½	1404	890	127.8	102.1	890	127.8	101.0	770	109.4	90.0
30	250	HRA30-25	R-70A	HPL30-25	PL-70A	89 x 30¼ x 71½	1774	890	127.8	102.1	890	127.8	101.0	770	109.4	90.0

VERTICAL TANK MOUNTED UNITS — ELECTRIC DRIVEN								125 PSI Rating*			175 PSI Rating*			250 PSI Rating*		
Motor HP	Tank Cap Gal.	R-Series CASRSA	Pump Comp Model	PL-Series CBSPLA	Pump Comp Model	L x W x H Dimensions inches	Aprox. Ship Wt.lbs.	RPM	CFM Displ.	CFM Del'y	RPM	CFM Displ.	CFM Del'y	RPM	CFM Displ.	CFM Del'y
1½	60	VR1-6	R-10D	NA	NA	30½ x 24 x 76	400	575	11.2	6.0	542	10.5	5.3	NA	NA	NA
1½	80	VR1-8	R-10D	NA	NA	32½ x 24 x 75	425	575	11.2	6.0	542	10.5	5.3	NA	NA	NA
2	60	VR2-6	R-10D	NA	NA	30½ x 24 x 76	425	765	14.9	8.3	725	14.1	7.5	NA	NA	NA
2	80	VR2-8	R-10D	NA	NA	32½ x 24 x 75	455	765	14.9	8.3	725	14.1	7.5	NA	NA	NA
3	60	VR3-6	R-15B	VPL3-6	PL-15A	30½ x 24 x 76	425	485	14.1	10.9	440	12.8	9.7	380	11.0	8.0
3	80	VR3-8	R-15B	VPL3-8	PL-15A	32½ x 24 x 75	485	485	14.1	10.9	440	12.8	9.7	380	11.0	8.0
3	120	VR3-12	R-15B	VPL3-12	PL-15A	36 x 30 x 81	725	485	14.1	10.9	440	12.8	9.7	380	11.0	8.0
5	60	VR5-6	R-15B	VPL5-6	PL-15A	30½ x 24 x 76	445	805	23.5	19.1	710	20.7	16.5	640	18.6	13.6
5	80	VR5-8	R-15B	VPL5-8	PL-15A	32½ x 24 x 75	545	805	23.5	19.1	710	20.7	16.5	640	18.6	13.6
5	120	VR5-12	R-15B	VPL5-12	PL-15A	36 x 30 x 81	765	805	23.5	19.1	710	20.7	16.5	640	18.6	13.6
7½	80	VR7F-8	R-15B	VPL7F-8	PL-15A	32½ x 24 x 75	635	990	28.7	23.9	990	28.7	23.1	870	25.5	18.2
7½	120	VR7F-12	R-15B	VPL7F-12	PL-15A	36 x 30 x 81	765	990	28.7	23.9	990	28.7	23.1	870	25.5	18.2
7½	80	VR7-8	R-30D	VPL7-8	PL-30A	42½ x 30 x 66¾	665	670	39.6	30.0	575	33.5	25.8	520	30.2	21.3
7½	120	VR7-12	R-30D	VPL7-12	PL-30A	43½ x 30 x 81	800	670	39.6	30.0	575	33.5	25.8	520	30.2	21.3
10	80	VR10-8	R-30D	VPL10-8	PL-30A	42½ x 30 x 66¾	860	810	48.5	37.3	740	43.1	34.8	640	37.1	27.5
10	120	VR10-12	R-30D	VPL10-12	PL-30A	43½ x 30 x 81	890	810	48.5	37.3	740	43.1	34.8	640	37.1	27.5
15	120	VR15F-12	R-30D	VPL15F-12	PL-30A	43½ x 30 x 81	890	1045	63.5	50.2	1045	63.5	49.0	900	52.5	42.6

\*Pressure Lubricated units are capable of 250 PSIG operation; units tested in accordance with CAGI/PNEUROP Acceptance Test Code PN2CPTC2.

## SPECIFICATIONS

BASE MOUNTED UNITS															
Motor HP	R-Series CABRSA	Pump Comp Model	PL-Series CBBPLA	Pump Comp Model	L x W x H Dimensions inches	Aprox. Ship Wt.lbs.	125 PSI Rating*			175 PSI Rating*			250 PSI Rating*		
							RPM	CFM Displ.	CFM Del'y	RPM	CFM Displ.	CFM Del'y	RPM	CFM Displ.	CFM Del'y
1½	BR-1	R-10D	NA	NA	34½ x 19¾ x 29½	205	575	11.2	6.0	542	10.5	5.3	NA	NA	NA
2	BR-2	R-10D	NA	NA	34½ x 19¾ x 29½	205	765	14.9	8.3	725	14.1	7.5	NA	NA	NA
3	BR-3	R-15B	BPL-3	PL-15A	34½ x 19¾ x 29½	230	485	14.1	10.9	440	12.8	9.7	380	11.0	8.0
5	BR-5	R-15B	BPL-5	PL-15A	34½ x 19¾ x 29½	280	805	23.5	19.1	710	20.7	16.5	640	18.6	13.6
7½	BR-7F	R-15B	BPL-7F	PL-15A	34½ x 19¾ x 29½	310	990	28.7	23.9	990	28.7	23.1	870	25.5	18.2
7½	BR-7	R-30D	BPL-7	PL-30A	41½ x 22¼ x 28¾	430	670	39.6	30.0	575	33.5	25.8	520	30.2	21.3
10	BR-10	R-30D	BPL-10	PL-30A	41½ x 22¼ x 28¾	540	810	47.3	37.3	740	43.1	34.8	640	37.1	27.5
15	BR-15F	R-30D	BPL-15F	PL-30A	49½ x 26½ x 28¾	550	1045	60.9	50.2	1045	60.9	49.0	900	52.5	42.6
15	BRA-15	R-40A	BPL-15	PL-40A	49½ x 27½ x 38	730	890	71.1	59.0	770	61.5	53.7	700	55.9	45.8
20	BRA-20	R-70A	BPL-20	PL-70A	54½ x 28½ x 39½	1000	770	109.0	91.9	655	93.0	76.7	545	77.4	64.1
25	BRA-25	R-70A	BPL-25	PL-70A	54½ x 28½ x 39½	1020	890	127.8	102.1	770	109.4	90.1	660	93.7	76.8
30	BRA-30	R-70A	BPL-30	PL-70A	54½ x 28½ x 39½	1059	890	127.8	102.1	890	127.0	101.1	770	109.4	90.0

TANK MOUNTED DUPLEX UNITS																
Motor HP	Tank Cap Gal.	R-Series CADRSA	Pump Comp Model	PL-Series CBDPLA	Pump Comp Model	L x W x H Dimensions inches	Aprox. Ship Wt.lbs.	125 PSI Rating*			175 PSI Rating*			250 PSI Rating*		
								RPM	CFM Displ.	CFM Del'y	RPM	CFM Displ.	CFM Del'y	RPM	CFM Displ.	CFM Del'y
2 (2)	80	HR2D-8	R-10D	NA	NA	66¾ x 28 x 51¾	715	765	29.8	16.6	725	28.2	15.0	NA	NA	NA
2 (2)	120	HR2D-12	R-10D	NA	NA	70½ x 28 x 55¼	940	765	29.8	16.6	725	28.2	15.0	NA	NA	NA
3 (2)	80	HR3D-8	R-15B	HPL3D-8	PL-15A	66¾ x 28 x 51¾	725	485	28.2	21.8	440	25.6	19.4	380	22.0	16.0
3 (2)	120	HR3D-12	R-15B	HPL3D-12	PL-15A	70½ x 28 x 55¼	950	485	28.2	21.8	440	25.6	19.4	380	22.0	16.0
5 (2)	80	HR5D-8	R-15B	HPL5D-8	PL-15A	66¾ x 28 x 51¾	755	805	47.0	38.2	710	41.4	33.0	640	37.2	27.2
5 (2)	120	HR5D-12	R-15B	HPL5D-12	PL-15A	70½ x 28 x 55¼	980	805	47.0	38.2	710	41.4	33.0	640	37.2	27.2
7½ (2)	120	HR7DF-12	R-15B	HPL7DF-12	PL-15A	70½ x 28 x 55¼	1150	990	57.4	47.8	990	57.4	46.2	870	51.0	36.4
7½ (2)	250	HR7DF-25	R-15B	HPL7DF-25	PL-15A	87½ x 32¾ x 50¼	1485	990	57.4	47.8	990	57.4	46.2	870	51.0	36.4
7½ (2)	120	HR7D-12	R-30D	HPL7D-12	PL-30A	86½ x 28½ x 56½	1305	670	79.2	60.0	575	67.0	51.6	520	60.4	42.6
7½ (2)	250	HR7D-25	R-30D	HPL7D-25	PL-30A	87½ x 32¾ x 61¾	1675	670	79.2	60.0	575	67.0	51.6	520	60.4	42.6
10 (2)	250	HR10D-25	R-30D	HPL10D-25	PL-30A	87½ x 29 x 62	1725	810	94.6	74.6	740	86.2	69.6	640	74.2	55.0
10 (2)	120	HR10D-12	R-30D	HPL10D-12	PL-30A	86½ x 29 x 57	1725	810	94.6	74.6	740	86.2	69.6	640	74.2	55.0
15 (2)	120	HR15DF-12	R-30D	HPL15DF-12	PL-30A	91¾ x 26½ x 48¾	1860	1045	121.8	100.4	1045	127.0	98.0	900	105.0	85.2
15 (2)	250	HR15DF-25	R-30D	HPL15DF-25	PL-30A	86½ x 29 x 57	1860	1045	121.8	100.4	1045	127.0	98.0	900	105.0	85.2
15 (2)	250	HRA15D-25	R-40A	HPL15D-25	PL-40A	89 x 54¾ x 73½	2460	890	142.2	118.0	770	123.0	107.4	700	111.8	91.6
20 (2)	250	HRA20D-25	R-70A	HPL20D-25	PL-70A	89 x 60½ x 75¼	2845	770	218.0	183.8	655	186.0	153.4	545	154.8	128.2
25 (2)	250	HRA25D-25	R-70A	HPL25D-25	PL-70A	89 x 60½ x 75¼	2940	890	255.6	204.2	770	218.8	180.2	660	187.4	153.6
30 (2)	250	HRA30D-25	R-70A	HPL30D-25	PL-70A	89 x 60½ x 75¼	3018	890	255.6	204.2	890	255.6	202.0	770	218.8	180.0

\*Pressure Lubricated units are capable of 250 PSIG operation; Units tested in accordance with CAGI/PNEUROP Acceptance Test Code PN2CPTC2.

ENGINE DRIVEN UNITS														
Motor HP	Tank Cap Gal.	R-Series CAERSA	Pump Comp Model	PL-Series CBEPLA	Pump Comp Model	L x W x H Dimensions inches	Splash Approx. Ship Wt.lbs.	Pressure Approx. Ship Wt.lbs.	175 PSI Rating**			250 PSI Rating**		
									RPM	CFM Displ.	CFM Del'y	RPM	CFM Displ.	CFM Del'y
8	30	HGR3-3B	R-15B	HGPL3-3B	PL-15A	38 x 22¾ x 45	345	345	600	17.5	14.8	NA	NA	NA
11	NA	BGR5H	R-15B	BGPL5H	PL-15A	36½ x 21 x 28¾	279	320	895	26.1	20.7	650	18.9	13.6
11	(2) 4	HGR5-LPH	R-15B	HGPL5-LPH	PL-15A	40 x 21¾ x 34¾	404	445	895	26.1	20.7	650	18.9	13.6
11	30	HGR5-3H	R-15B	HGPL5-3H	PL-15A	38 x 22¾ x 45½	409	450	895	26.1	20.7	650	18.9	13.6
11	60	HGR5-6H	R-15B	HGPL5-6H	PL-15A	52 x 23 x 49	475	514	895	26.1	20.7	650	18.9	13.6
11	80	HGR5-8H	R-15B	HGPL5-8H	PL-15A	66½ x 21 x 51	514	555	895	26.1	20.7	650	18.9	13.6
13	30	HGR7-3BB	RP15B	NA	NA	38 x 22¾ x 45½	460	500	1025	29.9	23.2	950	27.7	19.8
13	30	HGR7-3KB	RP15B	NA	NA	38 x 22¾ x 45½	410	460	1025	29.9	23.2	950	27.7	19.8
13	NA	BGR7-K	R-15B	BGPL7-K	PL-15A	40 x 21 x 29¼	279	279	1025	29.9	23.2	950	27.7	19.8
13	(2) 4	HGR7-LPK	R-15B	HGPL7-LPK	PL-15A	39⅞ x 21⅞ x 35	410	455	1025	29.9	23.2	950	27.7	19.8
13	30	HGR7-3K	R-15B	HGPL7-3K	PL-15A	38 x 22¾ x 45½	399	440	1025	29.9	23.2	950	27.7	19.8
13	60	HGR7-6K	R-15B	HGPL7-6HK	PL-15A	52 x 23 x 49	475	514	1025	29.9	23.2	950	27.7	19.8
13	80	HGR7-8K	R-15B	HGPL7-8K	PL-15A	66½ x 21 x 51	514	555	1025	29.9	23.2	950	27.7	19.8
20	NA	BGR10-K	R-30D	BGPL10-K	PL-30A	34 x 23 x 29	715	715	765	44.6	36.2	680	39.6	31.2
20	80	HGR10-8K	R-30D	HGPL10-8K	PL-30A	66½ x 21 x 49¾	715	715	765	44.6	36.2	680	39.6	31.2
23	5	BGR-12K	R-30D	BGPL-12K	PL-30A	46 x 28 x 35¾	645	645	940	55.0	44.2	810	47.2	38.4
35	5	BGRA-15	R-40A	BGPLA-15	PL-40A	63 x 41 x 49	1075	1075	910	72.8	59.0	800	64.0	51.5
*10	30	HDR5-3L	R-15B	HDPL5-3L	PL-15A	38 x 32 x 46	500	500	870	25.3	20.1	650	18.9	13.6
*10	NA	BDR5-L	R-15B	BDPL5-L	PL-15A	38¾ x 21 x 29¾	493	493	870	25.3	20.1	650	18.9	13.6
*10	80	HDR5-8L	R-15B	HDPL5-8L	PL-15A	66½ x 22 x 49	518	518	870	25.3	20.1	650	18.9	13.6
*10	30	HDR5-3Y	R-15B	HDPL5-3Y	PL-15A	38 x 32 x 46	500	500	870	25.3	20.1	650	18.9	13.6
*10	NA	BDR5-Y	R-15B	BDPL5-Y	PL-15A	38¾ x 21 x 29¾	493	493	870	25.3	20.1	650	18.9	13.6
*10	80	HDR5-8Y	R-15B	HDPL5-8Y	PL-15A	66½ x 22 x 49	518	518	870	25.3	20.1	650	18.9	13.6
*25	(2) 4	BDRA-15	R-40A	BDPL-15	PL-40A	52 x 29 x 42	813	813	910	72.8	59.0	800	64.0	51.5

NOTE: Pressure lubricated units are capable of 250 PSIG operation. 20 HP and larger packages do not come equipped with a fuel tank.

\*Diesel Driven \*\*Units tested in accordance with CAGI/PNEUROP Acceptance Test Code PN2CPTC3.

BARE PUMPS														
Motor HP	R-Series CAPRSA	PL-Series CBPPLA	Displ./Rev cubic feet	125 PSI Rating		175 PSI Rating		250 PSI Rating		Bore inches dia.	Stroke inches	Number cylinders	Oil Capacity quarts	Aprox. Ship Weight pounds
				RPM	CFM Del'y	RPM	CFM Del'y	RPM	CFM Del'y					
1½	R-10D	NA	.01942	575	6.0	542	5.3	NA	NA	4⅝ & 2½	2	2	2	125
2	R-10D	NA	.01942	765	8.3	725	7.5	NA	NA	4⅝ & 2½	2	2	2	125
5	RP15B	NA	.02916	805	19.1	710	16.5	NA	NA	4⅝ & 2½	3	2	2	125
3	R-15B	PL-15A	.02916	485	10.9	440	9.7	380	8.0	4⅝ & 2½	3	2	2	125
5	R-15B	PL-15A	.02916	805	19.1	710	16.5	640	13.6	4⅝ & 2½	3	2	2	125
7½	R-15B	PL-15A	.02916	990	23.9	990	23.1	870	18.2	4⅝ & 2½	3	2	2	125
7½	R-30D	PL-30A	.05828	670	30.0	575	25.8	520	21.3	4⅝ & 2½	3	4	4	220
10	R-30D	PL-30A	.05828	810	37.3	740	34.8	640	27.5	4⅝ & 2½	3	4	4	220
15	R-30D	PL-30A	.05828	1045	50.2	1045	49.0	900	42.6	4⅝ & 2½	3	4	4	220
15	R-40A	PL-40A	.0800	890	59.0	770	53.7	700	45.8	6¼ & 3¼	4½	2	4	440
20	R-70A	PL-70A	.1420	770	91.9	655	76.7	545	64.1	6¼ & 3¼	4	4	6½	570
25	R-70A	PL-70A	.1420	890	102.1	770	90.1	660	76.8	6¼ & 3¼	4	4	6½	570
30	R-70A	PL-70A	.1420	890	102.1	890	101.0	770	90.0	6¼ & 3¼	4	4	6½	570

# The Champion Assembled Unit Warranties

## Compressor Pump Warranty

Each new Champion Assembled Unit has a five (5) year warranty on the compressor pump only, against defects in materials or workmanship under normal use and service, from the date of installation or sixty-six (66) months from the date of shipment by Champion or a Champion distributor, whichever may occur first.

The five-year extended warranty covers parts and labor and is prorated over the five years as follows:

- Year One — 100% coverage
- Year Two — 90% coverage
- Year Three — 80% coverage
- Year Four — 70% coverage
- Year Five — 60% coverage

Head valves are warranted for Year One only. Champion makes no warranty on components and/or accessories furnished to Champion by third parties, such as electric motors, gasoline engines and controls. These are warranted only to the extent of the original manufacturer's warranty to Champion. Electric motors must be equipped with thermal overload protection to have warranty consideration.

The extended five-year warranty will apply to ASME air receivers if they are installed on rubber vibro isolator pads or approved equivalent.

## 5 Year Electric Motor

Any Champion package purchased after January 1, 2003 built with a Baldor electric motor are warranted for 60 months from start-up or 63 months from shipment. Other manufacturer's motors furnished due to customer request or special requirements carry the motor manufacturer's warranty.

## Limited Warranty

Warranty shall not apply to any equipment which has been subjected to misuse, neglect or accident, nor shall it apply to any equipment that has been repaired or altered by any person(s) not authorized by Champion. Failure caused by lack of proper maintenance is not covered by warranty.

In no event shall Champion be liable for consequential damages or contingent liabilities arising out of failure of any compressor or part to operate properly. When a compressor pump or component is changed or replaced during the warranty period, the new/replaced item(s) is warranted for only the remainder of the original warranty period. Complete warranty details are included in compressor operating manual.

## Package Warranty

Champion warrants each new air compressor package to be free from defects in material and workmanship under normal use and service for a period of one year (12 months) from the date of installation or 15 months from the date of shipment by Champion.

## U.L. Standards

Champion, in common with other major, industrial compressor manufacturers, does not market compressors which are U.L. listed. In general, U.L. is concerned with electrical components that may be utilized on compressor units, rather than a complete compressor package or system. All electrical components used on Champion compressors are U.L. listed. Each component – motor, starter, pressure switch, control panel – carries a U.L. identification mark on the nameplate or inside the electrical enclosure cover. The mark will be the letters "UR" reversed (as if held up to a mirror), indicating the item is "recognized" by U.L. On tankmounted units, the air receiver tank and tank pressure relief valve are ASME Code. The tank carries a National Board Registration number which appears on a stamped, metal plate welded to the tank.



1301 North Euclid Avenue  
Princeton, Illinois 61356 USA  
Phone 888/436-5499  
Fax 815/872-0421  
E-mail: [Champion@championpneumatic.com](mailto:Champion@championpneumatic.com)  
[www.ChampionPneumatic.com](http://www.ChampionPneumatic.com)