



Nuvair Nomad Gas

Rev 2.18

If you have any questions on this equipment please contact Technical Support at:

Nuvair
1600 Beacon Place
Oxnard, CA 93033

Phone: +1-805-815-4044
FAX: +1-805-486-0900
Email: info@nuvair.com

Hours: Monday through Friday
8:00 AM to 5:00 PM PST USA

If you lose this manual, you can download the latest version at www.nuvair.com.

Warning

This Operation Manual contains important safety information and should always be available to those personnel operating this equipment. Read, understand, and retain all instructions before operating this equipment to prevent injury or equipment damage.

Every effort was made to ensure the accuracy of the information contained within. Nuvair, however, retains the right to modify its contents without notice. If you have problems or questions after reading the manual, stop and call Nuvair at 1-805-815-4044 for information.

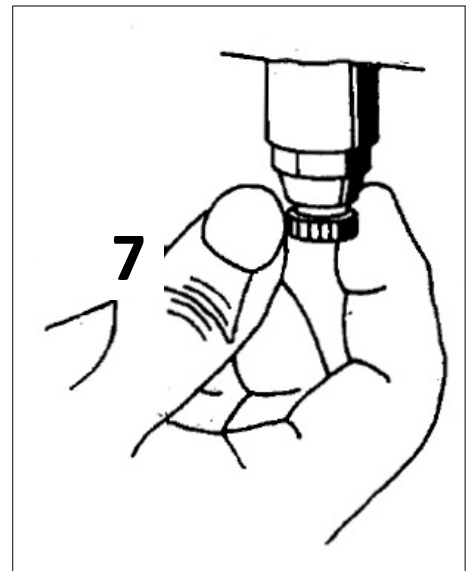
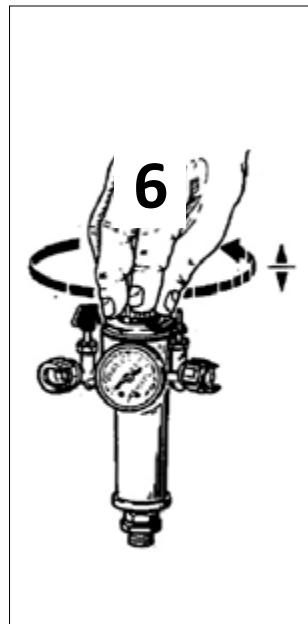
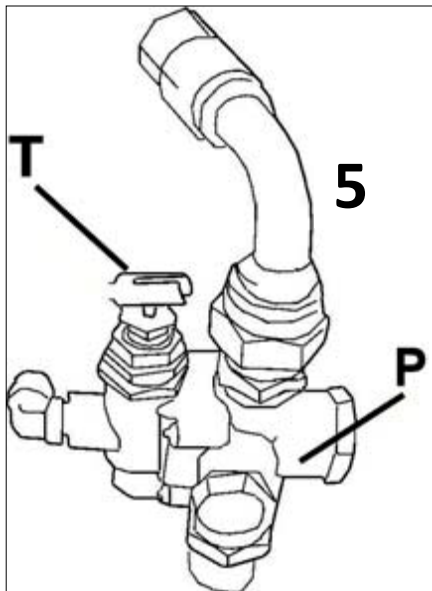
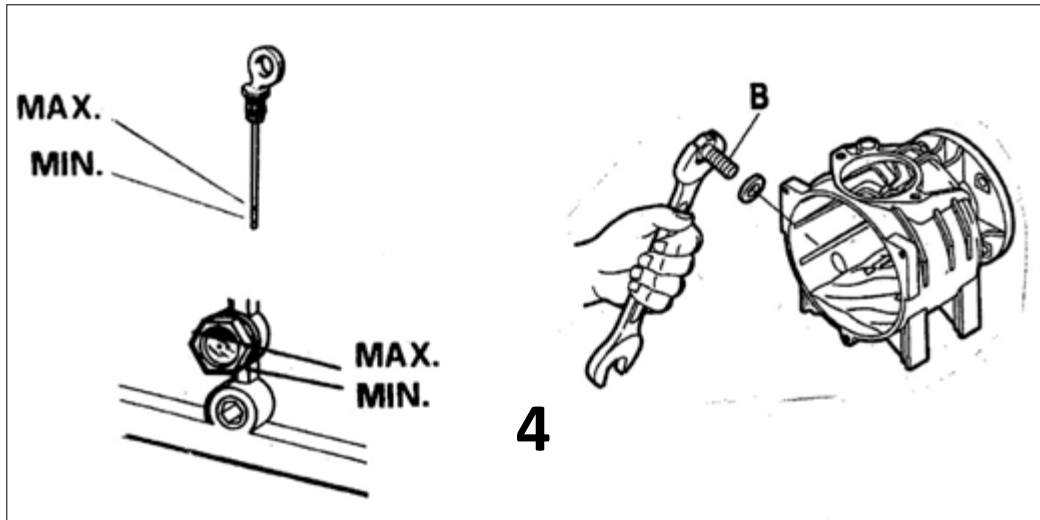
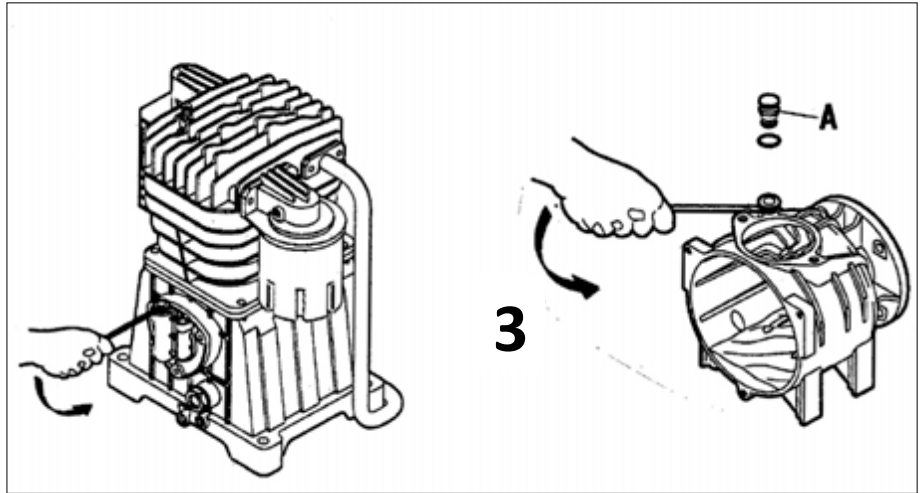
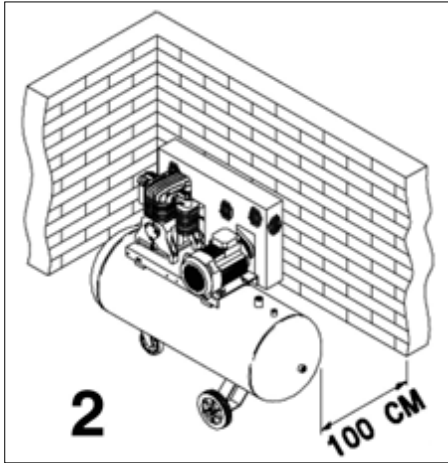

IMPORTANT INFORMATION

Read and understand all of the operating instructions, safety precautions and warnings in the Instruction Manual before operating or maintaining this compressor. Most accidents that result from compressor operation and maintenance are caused by the failure to observe basic safety rules or precautions. An accident can often be avoided by recognizing a potentially hazardous situation before it occurs, and by observing appropriate safety procedures. Basic safety precautions are outlined in the "SAFETY" section of this Instruction Manual in the sections which contain the operation and maintenance instructions. Hazards that must be avoided to prevent bodily injury or machine damage are identified by WARNINGS on the compressor and in this Instruction Manual. Never use this compressor in a manner that has not been specifically recommended by manufacturer, unless you first confirm that the planned use will be safe for you and others.

MEANINGS OF SIGNAL WORDS

WARNING: indicates a potentially hazardous situations which, if ignored, could result in serious personal injury.

CAUTION: indicates a hazardous situations which, if ignored, could result in moderate personal injury, or could cause machine damage.

NOTE: emphasizes essential information

SAFETY

IMPORTANT SAFETY INSTRUCTIONS FOR USE OF THE COMPRESSOR.

WARNING: DEATH OR SERIOUS BODILY INJURY COULD RESULT FROM IMPROPER OR UNSAFE USE OF COMPRESSOR. TO AVOID THESE RISKS, FOLLOW THESE BASIC SAFETY INSTRUCTIONS.

READ ALL INSTRUCTIONS

1. NEVER TOUCH MOVING PARTS

Never place your hands, fingers or other body parts near the compressor's moving parts. Never insert your fingers or other objects into the belt guard ventilator. Such an action invites the danger of injuries.

2. NEVER OPERATE WITHOUT ALL GUARDS IN PLACE

Never operate this compressor without all guards or safety features in place and in proper working order. If maintenance or servicing requires the removal of a guard or safety features, be sure to replace the guards or safety feature before resuming operation of the compressor.

3. ALWAYS WEAR PROTECTION

Always wear safety goggles or equivalent eye protection. Compressed air must never be aimed at anyone or any part of the body. Use ear protection as air flow noise is loud when draining.

4. STOP THE ENGINE.

Always stop the engine and pull out the spark plug cap to prevent any sudden start of the engine and remove the compressed air from the air tank before servicing, inspecting, maintaining, cleaning replacing or checking any parts.

5. STORE COMPRESSOR PROPERLY.

When not in use, the compressor should be stored in indoor dry place. Keep out of reach of children. Lock-out the storage area. Do not store this compressor near an open flame or any equipment such as a stove, furnace, water heater, etc. which utilizes a pilot light or sparking device. Store flammable materials in a secure location away from the compressor.

6. KEEP WORK AREA CLEAN

Cluttered areas invite injuries. Clear all work areas of unnecessary tools, debris, furniture etc.

7. CONSIDER WORK AREA ENVIRONMENT.

Don't expose compressor to rain. Don't use compressor in damp or wet locations. Keep work area well lit and well ventilated. Operate this compressor at a stable place all the time. Risk of fire or explosion. Do not carry and operate the compressor or any other electrical device near the spray area. Do not use compressor in the presence of flammable liquids or gases. Restricting any of the compressor ventilation openings will cause serious overheating and could cause fire. Never place objects against or on top of compressor. Gasoline engines produce carbon monoxide; a poisonous odorless gas which may cause death. Do not start or operate this compressor in an enclosed area. Operate compressor in an open area at least 4 feet away from any wall or obstruction that would restrict the flow of fresh air to the ventilation openings. Compressor produces sparks during operation. Never use compressor in sites containing lacquer, paint, benzine, thinner, gasoline, gases, adhesive agents, and other materials which are combustible or explosive. This compressor contains some components parts that tend to produce arcs or sparks, and therefore, when located in a garage, it should be in a room or enclosure provided for this purpose, and should be 18 inches (457 mm) or more above the floor. A spark arrester must be added to the muffler of this engine if it is to be used on any forest covered, brush covered or grass covered unimproved land. The arrester must be maintained in effective working condition by the operator. In order to avoid damaging this compressor, do not allow the unit to be tilted more than 10° when operating.

8. KEEP CHILDREN AWAY

All visitors should be kept safely away from work area.

9. DRESS PROPERLY

Do not wear loose clothing or jewelry. They can be caught in moving parts. Wear protective hair covering to contain long hair.

10. MAINTAIN COMPRESSOR WITH CARE

Follow instructions for lubricating.

11. STAY ALERT

Watch what you are doing. Use common sense. Do not operate compressor when you are tired. Compressor should never be used by you if you are under the influence of alcohol, drugs or medication that makes you drowsy.

12. CHECK DAMAGED PARTS AND AIR LEAK

Before further use of the compressor, a guard or other part is damaged should be carefully checked to determine that it will operate properly and perform its intended function. Check for alignment of moving parts, binding of moving parts, breakage of parts, mounting, air leak, and any other conditions that may affect its operation. A guard or other part that is damaged should be properly repaired or replaced by an authorized service center unless otherwise indicated elsewhere in this Instruction Manual. Have defective switches replaced by authorized service center. Do not use compressor if switch does not turn it on and off.

13. NEVER USE COMPRESSOR FOR APPLICATIONS OTHER THAN THOSE SPECIFIED.

Never use compressor for applications other than those specified in the Instruction Manual. Never use compressed air for breathing or respiration.

14. HANDLE COMPRESSOR CORRECTLY

Operate the compressor according to the instructions provided herein. Never allow the compressor to be operated by children, individuals unfamiliar with its operation or unauthorized personnel. Carrying the compressor if tilted may result in fuel spillage.

15. KEEP ALL SCREWS, BOLTS AND COVERS TIGHTLY IN PLACE

Keep all screws, bolts, and plates tightly mounted. Check their conditions periodically.

16. NEVER USE A COMPRESSOR WHICH IS DEFECTIVE OR OPERATING ABNORMALLY

If the compressor appears to be operating unusually, making strange noises, or otherwise appears defective, stop using it immediately and arrange for repairs by a authorized service center.

17. DO NOT WIPE PLASTIC PARTS WITH SOLVENT

Solvents such as thinner, benzine, carbon tetrachloride, and alcohol may damage and crack plastic parts. Do not wipe them with such solvents. Wipe plastic parts with a soft cloth lightly **GB** dampened with soapy water and dry thoroughly.

18. USE ONLY GENUINE REPLACEMENT PARTS Replacement parts not original may void your warranty and can lead to malfunction and resulting injuries. Genuine parts are available from your dealer.

19. DO NOT MODIFY THE COMPRESSOR

Do not modify the compressor. Always contact the authorized service center any repairs. Unauthorized modification may not only impair the compressor performance but may also result in accident or injury to repair personnel who do not have the required knowledge and technical expertise to perform the repair operations correctly.

20. TURN OFF THE SWITCH WHEN THE COMPRESSOR IS NOT USED

When the compressor is not used, turn off switch and open the drain cock to discharge the compressed air from the air tank.

21. NEVER TOUCH HOT SURFACE

To reduce the risk of burns, do not touch tubes, heads, cylinder and muffler. Never allow any part of your body or other materials to contact with any exposed metal parts on this compressor. Never allow any part of your body to contact the muffler or adjacent areas. These areas can remain hot for least 45 minutes after this compressor is shutdown. Cool down before servicing.

22. DO NOT DIRECT AIR STREAM AT BODY

Risk of injury, do not direct air stream at persons or animals.

23. DRAIN TANK

Risk of bursting. Water will condense in the air tank. If not drained, water will corrode and weaken the air tank causing a risk of air tank rupture. Drain tank daily or after 4 hours of use. The drain contains moisture in the air, abrasion particles, rust, etc. To drain tank open valve slowly and tilt compressor to empty accumulated water. Keep face and eyes away from drain cock.

24. MAKE SURE THE COMPRESSOR OUTLET PRESSURE IS SET LOWER THAN THE MAXIMUM OPERATING PRESSURE OF THE TOOL.

Too much air pressure causes a hazardous risk of bursting. Check the manufacturer's maximum pressure rating for air tools and accessories. The regulator outlet pressure must never exceed the maximum pressure rating.

25. THE SAFETY VALVE MUST WORK PROPERLY.

Risk of bursting. Before starting the compressor pull the ring on the safety valve to make sure the valve moves freely. If the safety valve does not work properly, over-pressurization may occur, causing air tank rupture or an explosion.

26. SEE TO IT THAT FUEL IS SUPPLIED APPROPRIATELY.

Follow all fueling instructions in operator's manual. Gasoline is extremely flammable, and gasoline vapor can explode. Do not refuel tank while this compressor is running or hot. Never smoke near gasoline, and keep other flames and sparks away. Do not refuel indoors or in a poorly ventilated area. Do not fill fuel tank to point of overflowing. Always refuel slowly to avoid the possibility of spilled fuel which may cause a fire. Do not operate this compressor if gasoline is spilled. Wipe this compressor clean and move it away from the spill. Avoid creating any ignition until the gasoline has evaporated. Allow approximately 1/4" of tank space for fuel expansion. Always store fuel away from this compressor while it is running or hot. Always store gasoline in an approved container.

27. BE CAREFUL NOT TO TRIP OVER OR DROP THE COMPRESSOR DURING TRANSPORT.

Exercise utmost caution when you carry this compressor. If you trip over something and drop it, there is a fear that unexpected injury may result. If you drop this compressor or bump it against any objects, air tank or any component parts can cause serious deformation, damage, severe scratches and breakdown on this compressor. If operated under such conditions, it can result in any accidents or bodily injuries by explosion of the air tank or explosion of those damaged component parts. Furthermore, gasoline which spilled out by those damages, may have a great risk of a fire. When there is any deformation and damage on the handle, it may drop during transport, resulting in an accident of injury. Before carrying this compressor, switch off the engine and discharge the drain inside the air tank. Be cautious enough to make sure that there are no obstacles, inflammable articles, and unauthorized people around this compressor.

REPLACEMENT PARTS

When servicing use only identical replacement parts. Repairs should be conducted only by authorized service center.

**SAVE THESE INSTRUCTION AND
MAKE THEM AVAILABLE TO OTHER USERS OF THIS TOOL!**

OPERATION AND MAINTENANCE

NOTE: The information contained in this Instruction Manual is designed to assist you in the safe operation and maintenance of the compressor. Some illustrations in this Instruction Manual may show details or attachments that differ from those on your own compressor.

INSTALLATION

Remove the compressor from its packing (fig.1), makes sure it is in perfect condition, checking if it was damaged during transport, and carry out the following operations. Fit the wheels and rubber tab on the tanks on which they are not already fitted, observing the instructions in fig.1. In case of inflatable wheels, the maximum inflation pressure must be of 1,6 bar (24 psi). Position the compressor on a flat surface or with a maximum permissible inclination of 10°, in a well aired place, protected against atmospheric agents and not in a place subject to explosion hazard. To ensure good ventilation and efficient cooling, the compressor's belt guard must be at least 100 cm from any wall (fig. 2).

Do not place this compressor in an area:

- where there is evidence of oil or gas leaks.
- where flammable gas vapors or materials may be present.
- where air temperatures fall below 0°C or exceed 35°C.
- where extremely dirty air or water could be drawn into this compressor.

USE INSTRUCTIONS

– Take care to transport the compressor correctly, do not overturn it or lift it with hooks or ropes.

Replace the plastic plug on the guard cover with the oil level stick or with the relevant breather plug, supplied with the instructions booklet. Check oil level, consulting the reference marks on the stick or the oil level inspection window (fig. 3-4).

For S13 – 15/20 engine-driven compressors, unscrew the cap on the side of the casing and check that the oil is at the level of the spout.

Engine

WARNING: Do not allow the engine or muffler to come in contact with flammable vapors, combustible dust, gases or other combustible materials. A spark may cause a fire. Do not place this compressor in an area where flammable gas vapors may be present.

- Read the engine manual accompanying this compressor for correct engine start-up maintenance procedures.
- Read and understand the safety labels located on this compressor.
- Use only gasoline with this compressor. Do not mix with diesel.
- Check the engine oil level before starting (See engine manual).
- Fill the fuel tank according to the engine manual instructions.

WARNING: Follow all fueling instructions in operator's manual. Do not fill fuel tank while this compressor is running or hot. Never smoke near fuel, and keep other flames and sparks away. Allow this compressor and engine to cool down before refueling. Do not refuel indoors or in a poorly ventilated area. Do not fill fuel tank to point of overflowing. Always refuel slowly to avoid the possibility of spilled fuel which may cause a fire. Do not operate this compressor if fuel is spilled. Wipe this compressor clean and move it away from the spill. Avoid creating any ignition until the gasoline has evaporated. Allow approximately 1/4" of tank space for fuel expansion. Always store fuel away from this compressor while it is running or hot. Always store fuel in an approved container.

- Refer to the engine manual for all necessary maintenance and adjustments.

WARNING: Do not operate this compressor in an enclosed area. Use this compressor only in well ventilated areas. The exhaust from the engine contains carbon monoxide, a poisonous, odorless and invisible gas. Breathing the gas can cause serious injury, illness and possible death. Avoid inhalation of exhaust gas. Never run the engine in a closed garage or confined area.

Ensure the oil level in this compressor pump is adequate. If the oil level is low, replenish oil through the filling hole so that the amount of oil will come to the middle of the oil sight glass.

- Remove any moisture in this compressor air tank. Gradually open the drain cock and discharge the drain. Close tightly when drained.
- Make sure the engine switch is in the "OFF" position.
- Make sure all guards and covers are in place and securely mounted.

OPERATION

Start-up

- a. Read safety warnings before performing operation.
- b. When the toggle (T) is in the upright position, all air from this compressor is vented through the discharge muffler (fig.5). This gives an easy start feature. For normal operation, the toggle (T) is in the 90° position.
- c. Start engine (Refer to the Engine Manual accompanying this unit).
- d. When the engine has run for 1-2 minutes, flip toggle (T) back to the original position.
The operation of this compressor is automatic and is controlled by the pilot valve (P) which idles it when the pressure in the air-tank reaches the maximum level and restarts it when the air pressure drops during use to the restart level. The pilot valve is preset by the manufacturer and must not be modified in any way.

WARNING: If you notice any unusual noise or vibration, stop this compressor.

CAUTION: Wear appropriate personal hearing protection during use. Under some conditions and duration of use, noise from this product may contribute to hearing loss.

ADJUSTING OPERATING PRESSURE

You do not have to use the maximum operating pressure at all times. On the contrary, the equipment being used often requires less pressure. On compressors supplied with a pressure reducer, operating pressure must be correctly adjusted. Release the pressure reducer knob by pulling it up, adjust pressure to the required value by turning the knob clockwise to increase pressure and anti-clockwise to reduce it. When you have obtained optimum pressure, lock the knob by pressing it downward (fig. 6).

WARNING: Some pressure regulators do not have "push to lock", therefore simply turn the knob to adjust the pressure.

WARNING: Check the manufacturer's maximum pressure rating for equipment connected to the compressor and accessories. Compressor outlet pressure must be regulated so as to never exceed the maximum pressure rating for tools connected to the compressor.

	Standard	Optional
Food Grade Breathing Air Oil	Nuvair 455	Nuvair 751

Pre-start checklist

- 1. Oil level should be checked on a daily basis to ensure it does not exceed the maximum notch or does not fall below the minimum notch on the oil sight glass. If the oil level is low, replenish oil through the filling hole so that the amount of oil will come to a point between the maximum notch and the minimum notch of the oil sight glass.

CAUTION: Overfilling with oil will cause premature compressor failure. Do not overfill.

Shutdown

1. To stop this compressor, move the engine switch to the “Off” position (Refer to the Engine Manual accompanying this unit). b. Gradually open the drain cock, take out the drainage and all the compressed air inside the tank to prevent any internal corrosion of the tank (fig.7).

WARNING: Risk of bursting. When the tank gets corroded, there is a risk of breakdown. Water will condense in the air tank. If not drained, water will corrode and weaken the air tank causing a risk of air tank rupture. Drain tank daily or after 4 hours of use. The drain contains moisture in the air, abrasion particles, rust, etc. To drain tank open valve slowly and tilt compressor to empty accumulated water. Keep face and eyes away from drain cock.

2. Allow the compressor to cool down
3. Wipe this compressor clean and store in a safe, non-freezing area.

NOTE: The head/cylinder/delivery tube unit can reach high temperatures. Take care when working near these parts, and do not touch them to avoid possible burns (fig. 8).

WHAT TO DO IF SMALL MALFUNCTIONS OCCUR

Loss of air in check valve

This trouble depends on poor tightness of the check valve – take the following action (fig. 11):

- Discharge all pressure from the tank
- Unscrew the hexagon-head of the valve (A)
- Carefully clean both the rubber disk (B) and its seat.
- Refit all parts accurately.

Air losses

These can be caused by poor tightness of a union – check all unions, wetting them with soapy water.

Compressor turns but does not load

Coaxial compressors: (fig. 12)

- this may be due to failure of the valves (C1 – C2) or of a seal (B1 – B2): replace the damaged part. Pulley drive compressors: (fig. 13)
- this may be due to failure of the valves F1 and F2 or of a seal (D1 – D2): replace the damaged part.
- Check if there is too much condensate water inside the tank.

IMPORTANT

- Do not on any account unscrew any connection while the tank is pressurized – always check if the tank is pressure free.
- Do not drill holes, weld or purposely deform the compressed air tank.
- Do not do any jobs on the compressor unless it is off.
- Temperature in operating ambient: 0°C +35°C.
- Do not aim jets of water or inflammable liquids on the compressor.
- Do not place inflammable objects near the compressor.
- Never aim the air jet at people or animals
- Do not transport the compressor while the tank is pressurized.
 - Be careful with regard to some parts of the compressor such as the head and delivery tubes, as they can reach high temperatures. Do not touch these parts to avoid burns.
- Transport the compressor, lifting or pulling it with the appropriate grips or handles.
- Keep children and animals well away from the machine operating area.
- Make sure there is adequate exchange of air at the place of work
- Protect your nose and mouth with an appropriate mask. (fig.14)
- Do not put objects or your hands inside the protective grilles to avoid injury to yourself or damaging the compressor.
- Do not use the compressor as a blunt object toward things or animals, to avoid serious damage.
- When you have finished using the compressor, always switch it off.

MAINTENANCE

WARNING: Remove the compressed air from the air tank before performing the maintenance operations. Allow the compressor to cool before performing the maintenance operations. Always stop engine and pull out the spark plug cap to prevent any sudden start of the engine and remove this compressed air from the air tank before performing the maintenance operations.

Read the instruction manual before performing maintenance.

The following procedures must be performed when stopping the compressor for maintenance or service.

- A) Turn off the compressor.
- B) Disconnect spark plug wire from engine. C) Open all drains.
- D) Wait for this compressor to cool down before starting service.

1. Cleaning the air intake filter

This filter is designed to clean air coming into the pump (fig.9). To ensure the pump continually receives clean, cool, dry air supply this filter must always be clean and ventilation opening must always be free from obstructions.

WARNING: Never clean filtering element with a flammable liquid or solvent.

CAUTION: Do not operate without the intake filter. NOTE: Replace the filter element when it becomes dirty.

2. Draining tank:

Gradually open the drain valve, and drain out the air in the tank. Close tightly when drained.

- If using the compressor for painting:
 - a. Do not work in closed environments or near to naked flames
 - 3. Oil change-oil topping off (fig.10).
 - 4. Maintenance chart.

MAINTENANCE CHART

PROCEDURE	AFTER USE	DAILY	WEEKLY	MONTHLY	200 HOURS
Check pump oil level		X			
Oil leak inspection		X			
Drain condensation in air tank(s)	X	X			
Inspect guards/covers		X			
Check for unusual noise/vibration		X			
Check for air leaks		X			
Clean exterior of compressor			X		
Inspect air filter			X		
Check safety relief valve			X		
Inspect bel tension				X	
Change pump oil					X
Replace air filter					X

The pump oil must be changed after the first 50 hours of operation and every 200 hours or 3 months, whichever comes first. Open the pump oil cock and replace pump oil. As regards the engine, follow instructions in the engine manual. Every 2 years, an Authorized Service Technician should check the check valve, intake valves and delivery valves.

Compressors models	S1320-S100/240-S200/400-S300/550-S1520-AGRI	S16-S20-S24-S33
Maximum working pressure	12 bar	12 bar
Maximum utilization pressure	10 bar	11 bar

For the European market, the compressor tanks are manufactured to meet Directive CE87/404
 For the European market, the compressors are manufactured to meet Directive CE98/37.

Acoustic pressure measured free-field at a distance of 4m: $\pm 3\text{dB(A)}$ at maximum operating pressure.

MOD.	HP/CV	dB (A)
S1320	2,2	74
S16	4	74
S20 – S24	5,5	75
S33	9	77
S100/240	4	73
S200/400	5,5	78
S300/550	9	79
S1520 – S1506	4	75
S248/22	4	74
AGRI 45	4	75
AGRI 55–AGRI 65	5,5	77
AGRI 90/550	9	77
AGRI 90/670	9	76
AGRI 55 Diesel	5	77
AGRI 75 Diesel	7	77

The level of acoustic pressure can increase from 1 to 10 dB(A) according to the place in which the compressor is installed.

STORING THE PACKED AND UNPACKED COMPRESSOR

For the whole time that the compressor is not used before unpacking it, store it in a dry place at a temperature between +5°C and + 45°C and sheltered away from weather.

For the whole time that the compressor is not used after unpacking it, while waiting to start it up or due to production stoppages, place sheets over it to protect it from dust, which may settle on the components. The oil is to be replaced and the operational efficiency of the compressor is to be checked if it is not used for long periods.

PNEUMATIC CONNECTIONS

Make sure you always use pneumatic tubes for compressed air with maximum pressure characteristics that are adequate for the compressor.

Do not attempt to repair tubes if faulty.

**WE RESERVE THE RIGHT TO MAKE ANY MODIFICATIONS WITHOUT PRIOR NOTICE WHENEVER NECESSARY.
 WITHOUT PRIOR NOTICE WHENEVER NECESSARY.**

LP Feed Air Filtration



Special attention needs to be given to the arrangement of the LP Feed Air Filtration Elements and Bowls. Properly reinstall each Element and Bowl to the correct Housing. Improper sequence can cause damage to downstream components. The ball valve can be installed on either the inlet or outlet side. Housings must be installed in a vertical position to function properly.

Three stages of Norgren LP filtration are used to produce Grade D air:

- 1) Particle Removal to 1 micron
- 2) Coalescing & Water/Oil Vapor Removal to 0.01 micron
- 3) Oil Vapor Removal to 0.003 PPM

LP Filtration Inspection

Open each Filter and inspect as follows:

- 1) Inspect Bowl for the presence of moisture. A high level of moisture build-up in the B74G or F74H Filter indicates improper operation of auto-drain floats. Evidence of moisture in the F74V Filter indicates air is not cooling properly and moisture is not properly being removed. Excess moisture will prevent the final filter from operating properly.
- 2) Inspect Elements for any unusual degradation or wetness. Element degradation can indicate more serious problems. Contact Nuvair for assistance.

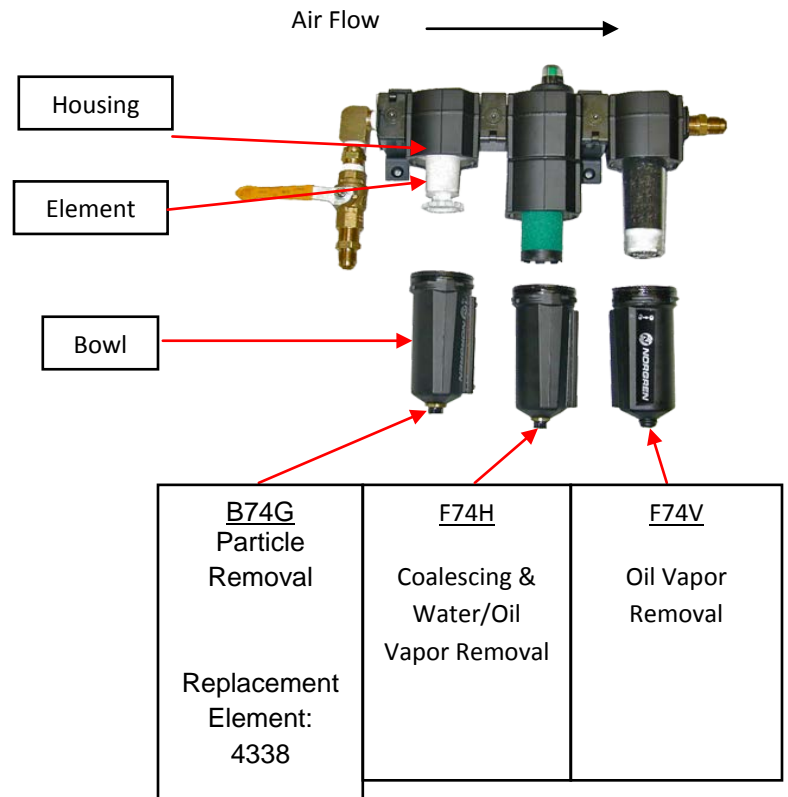

Service Indicator Changes from Green to Red as Filter Ages. Do Not Use When Red.

Liquid Level Indicator Shows if Auto Drain is Working Correctly.



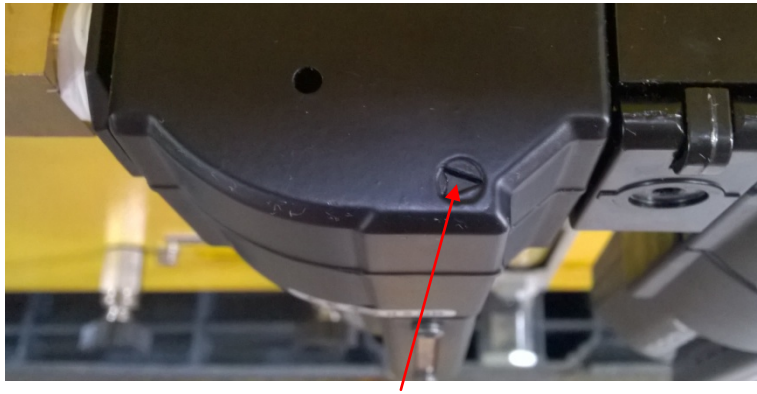

Air Flow Direction: The direction of air flow is shown by a stamped arrow.

Auto drains: Auto drains are in the first 2 filters. All moisture should be removed before the final filter so no drain is needed there. Make sure that all bowls are installed on the correct housing.

Changing LP Filtration Elements

Change Filter Elements every 100 hours. If operating in high humidity and/or high temperature, Filter Elements must be changed more often. Visual service indicators on the F74H filters assist with monitoring replacement intervals.

- 1) Push up on Filter Bowl, rotate counter-clockwise, and lower to remove.
- 2) Gently unscrew Filter Element and pull down off mounting post.
- 3) Replace Element and reassemble in reverse order.



Changing LP Filtration Element



The interior of the Filter Bowls can be cleaned with a diluted solution of Simple Green™ and flushed thoroughly with clean water. This will assist to prolong the life of the element, bowl, and auto drain.



Nuvair™

Phone +1-805-815-4044

Fax +1-805-486-0900

1600 Beacon Place

Oxnard, CA 93033

USA

Email : info@nuvair.com

Web : www.nuvair.com

Revision 2.18